



TOPIC:  
FENZI Warmedge (Industrielle) Spacer  
Technical Specifications

DATE: April 2008

## 1. Spacer Properties

### Cross Section and Tolerances

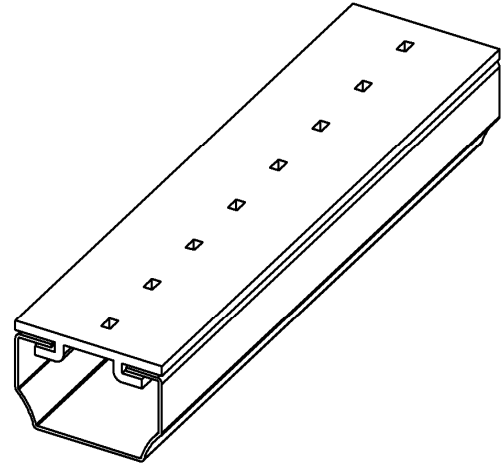
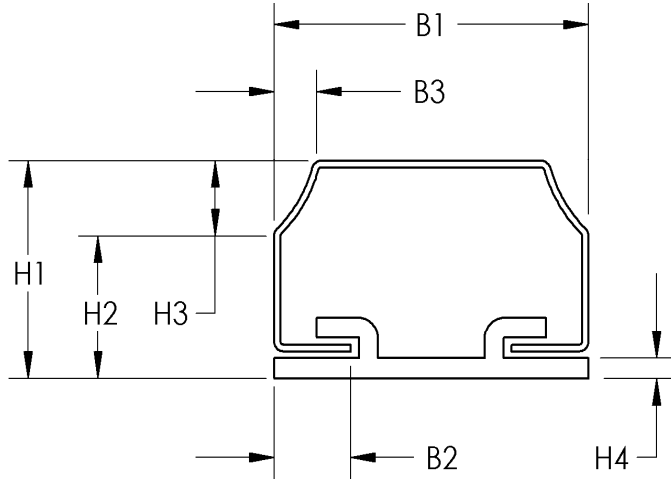

Description	Air Space Height * Fixed	PIB Flange * Fixed	Spacer Back Fill Cavity * Fixed	Thermal Bridge Thickness * Fixed	Air Spacer Width * Varies	Metal Spacer Lip * Fixed	Spacer Cavity Back Fill
Spacer Bar Width	H1 +/- .05	H2	H3	H4	B1 +/- .002	B2	B3
Warmedge 7/16	.280	.170	.110	.030	.437	.122	.068
Warmedge 1/2	.280	.170	.110	.030	.500	.122	.082
Warmedge 9/16	.280	.170	.110	.030	.562	.122	.085
Warmedge 5/8	.280	.170	.110	.030	.625	.122	.087
Warmedge 3/4	.280	.170	.110	.030	.750	.122	.100

**\*Please Note:**

Many dimensions fixed, with only the spacer width varying  
Electrolytic tin steel thickness fixed at .010 +/- .002



	Description	Internal Test Method
1.2	<b>Spacer geometry /shape</b> The spacer geometry shape is shown in the cross section picture above. Tolerances shown above	Slide gauge and inspection drift
1.3	<b>Length and straightness</b> Standard length is 13 feet +/- .25 inches. Straightness deviation .002	Steel ruler Visual
1.4	<b>Plastic</b> Rigid vinyl bridge applied via grooves in the PVC and with adhesive	Twirl test
1.5	<b>Perforation See comments below **</b> Measured with air flow. Typically spaced at .275	Flow meter

**\*\*1.5 Level of perforation**

The Fenzi Warmedge (Industrielle) standard perforation in the vinyl bridge will absorb moisture vapor, regardless of spacer width as perforations fixed

**\*\* 1.5 Function of the perforation**

The perforation holes are able to detain dust from the desiccant, from entering the air space.

## 2. Spacer Material

2.1	<b>Material</b> Electrolytic Tin Plate Steel Plastic Extrusion, meeting ASTM Density and Hardness specifications Available in white, black and grey colours	
2.2	<b>Surface</b> The surface is clean and free of contaminates, free of any chemicals.	Visual test & Adhesion test
2.3	<b>Tolerances of the material</b> The wall thickness of the metal spacer is at .010 +/- .005	Measure with gauge
2.4	<b>Lubrication</b> During the roll forming process, some lubrication is used. The lubrication is cleaned off and will evaporate, leaving the surface without any volatile elements.	Adhesion test
2.5	<b>Volatile elements</b> Volatile elements are tested according to the CGSB Can12.8 Canadian Fog Test	IG Testing

## 3. Quality Aspects

### Quality Management

Fenzi Warmedge (Industrielle) spacer has many customers IGMAC certified. It is currently listed in the IGMA Directory of Spacer Components.

### Tests of the Product

Processes and routines are established to secure the quality of the delivered materials to our customers. During the production process the spacers are constantly monitored through random checks for consistency in the finished spacer materials.

## 4. Customer Focus

To secure the performance of the spacers and maintain stock levels of finished goods at an acceptable amount. To continue to focus on our customers needs and develop addition products to meet these needs.